

THERE MAY BE 2 TO 4 BALLS LEFT OUT DUE TO MANUFACTURING PROCESS.

CAUTION: PROTECT BALLS AND RACES FROM SAWDUST, DIRT, PAINT, ETC. SHOULD BEARING BECOME "ROUGH" FROM DIRTY RACES, FLUSH THOROUGHLY WITH HOT SOAPY WATER, RINSE, OVEN DRY AND RE-OIL.

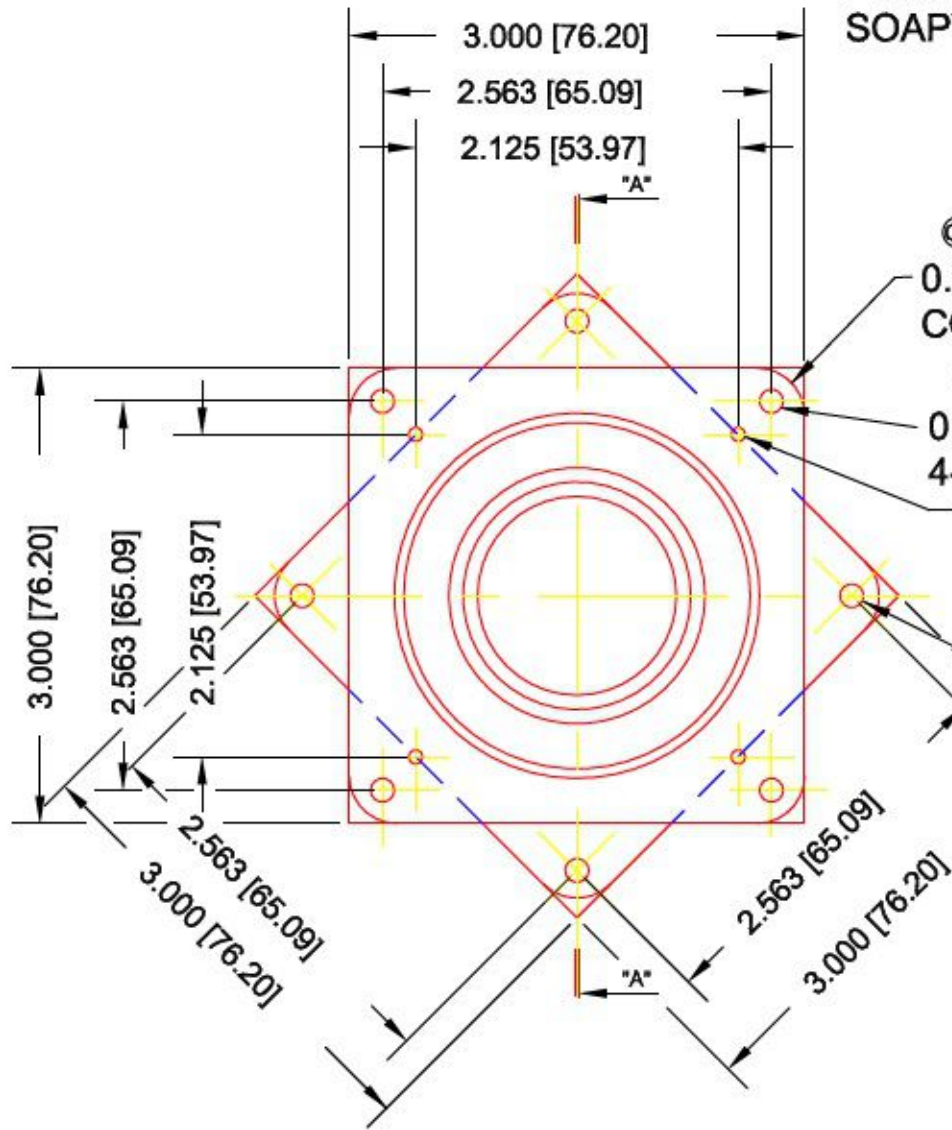

PART NO.

3C

0.313 [7.95] R. ON CORNERS AS MFG. OPTION.

0.156 [3.96] DIA. 4-HOLES FOR #6 SELF TAPPING SCREW 4-HOLES

0.156 [3.96] DIA. 4-HOLES

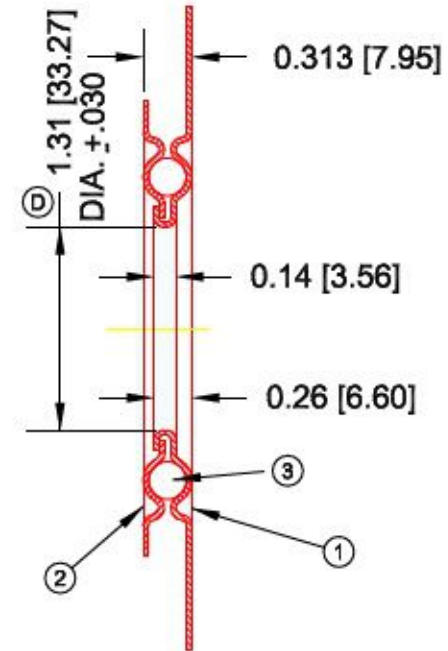

SECTION "A-A"

PART STAMPED WITH TRIANGLE NAME STAMP

QTY	PART NUMBER	DESCRIPTION	AMT
3	BALLS3	BALL	1
2	1089	PLAIN RACE	1
1	1101	LOCKING RACE	1

DET	PART NUMBER	DESCRIPTION	AMT
-----	-------------	-------------	-----

B TRIANGLE MANUFACTURING CO.

NAME 3" LAZY SUSAN BRG.

USED IN **////**

DATE 10-17-99

DRAWN SP
CHECKED MJK
SCALE 1 / 1

FIT	////
PLATING	ELECTRO-GALV
MATERIAL	SEE DET.
ALL DIMS ±.020 UNLESS SPECIFIED	

(F)

(H)

CHANGE LEVEL	H	02-18-09
--------------	---	----------